



EoL

END OF
LINE

914BVS VERTICAL BOX-MOTION WRAPPER



Delivers economical continuous motion tray wrapping

The 914BVS continuous motion vertical sealer is a moderate speed vertical shrink system capable of running products in an upright position.

You can achieve speeds up to 70 packs per minute on this precise sealing, centerline design machine. The advantages of vertical wrapping are available for products such as bottles, jars or cans in slower in-line or even off-line applications.

It's perfect for contract packagers where the products are often manually loaded to form multi-packs of an item.

FEATURES AND BENEFITS

- Easy to use
- Servo controlled
- Continuous motion
- Large product size capacity (8"W max, 14"H max)
- Low mount film unwind for easy loading
- Texwrap's exclusive patented Motion Trim™ for increased throughput speeds
- Independent conveyor control allows relaxed film at cross seal and transitions

TYPICAL PRODUCT SPECIFICATIONS

Conveyor Width	8-1/2"W
Cross Seal	9"W x 16"H End Seal
Cross Seal Drive	Servo Motor
Film Width	Max 48" Flat film, 24" Centerfolded
Electrical	240/208V, 40 Amp, 3 phase, 50/60 HZ

Air Requirements	Options only
Conveyor Height	Adj. from 31-1/2" to 38-1/2"
Max. Film Speed	140 FPM
Max. Cycle Rate	Up to 70 cycles / minute
Machine Controls	Allen Bradley PLC

* Specifications on all machines subject to change without notice. Some information may have been updated since the time of publication.

CONFIGURATION

Multiview

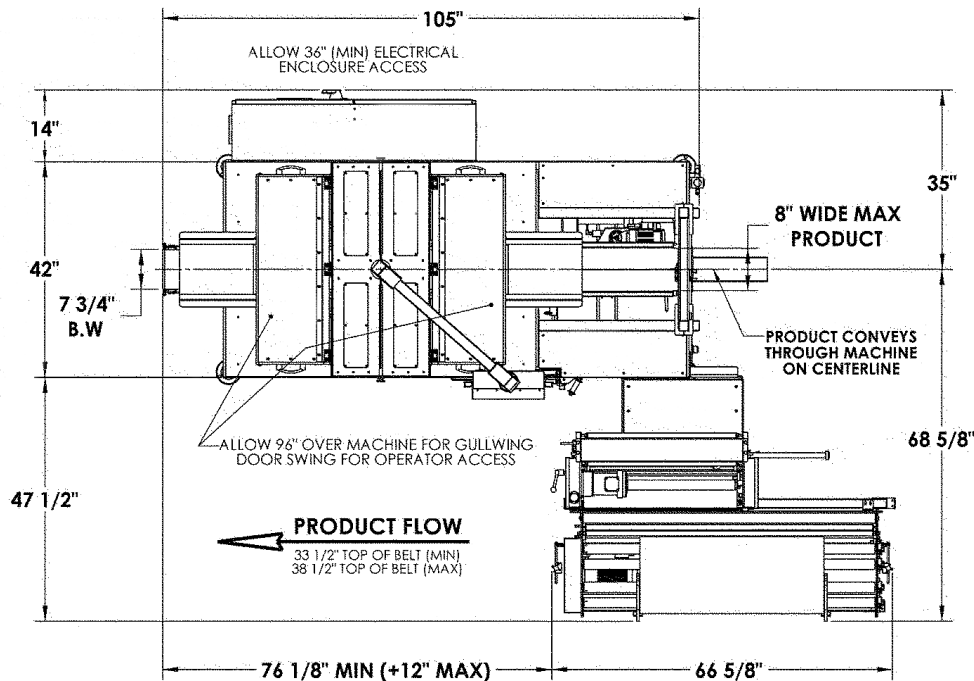

MORE ABOUT THE 914BVS

Both the horizontal movement and closing motion of the sealing head are servo controlled. In addition, the 914BVS has the capability to infinitely vary the speed of the exit conveyor which allows it to be slowed momentarily as the seal is being made to relieve tension on the film for superior seals using the minimum amount of film.

The model 914BVS uses a full bottom trim seal to securely enclose the product.

In addition to providing an outstanding seal, this system eliminates the unsightly side seal across the side panel of packages common in other machines.

If your application requires the wrapping of products in a vertical orientation at moderate speeds, the Texwrap model 914BVS is the answer.