



Machine Specification

67-08-5

Effective: July 16, 2018

Replaces: May 26, 2011

BEL 450

Poly-Bag Insert / Semi-Automatic Top & Bottom Case Tape Sealer

The BEL 450SS combines into a single unit the features of a packing station, semi-automatic case sealer, and a vacuum system for drawing plastic bags into empty cases. The operator partially erects a case on the vacuum plenum grate with the assistance of the rear minor flap folding jack and places an empty bag over the top open flaps where vacuum draws it down into the case. After the case is filled with bulk product, the operator seals the bag, folds down the top flaps then pushes the case into the sealer for top and bottom taping with 2" or 3" wide tape. A BEL *Uni-Drive* conveyor system, with a single motor synchronously driving both side-belts, holds cases securely and keeps them square. An optional scale system is available to weigh product on the vacuum plenum case grate. The power required is 120VAC single-phase for both the vacuum fan and sealer side-belt conveyor drive and it connects to an electrical outlet by a conventional cord and plug.

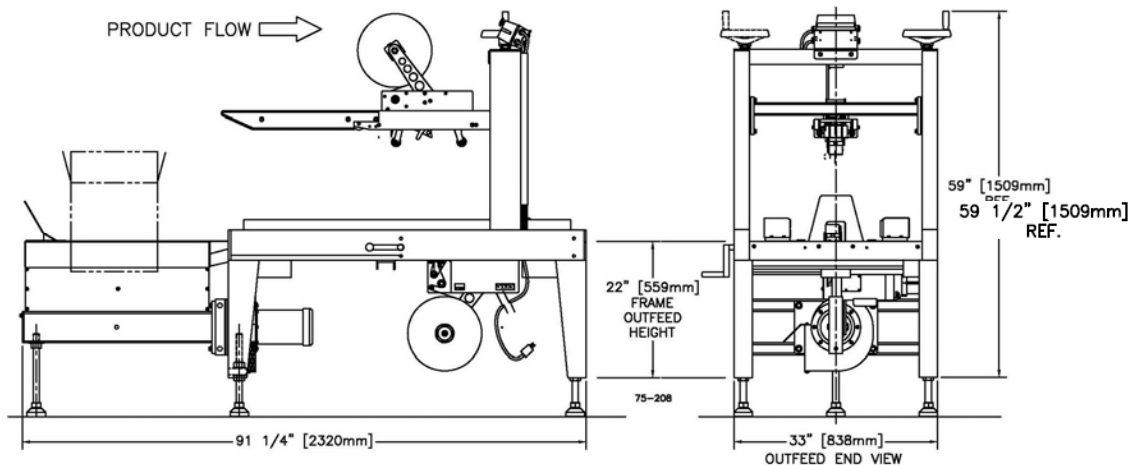

Standard Specifications

			Length	Width*	Height
Case Size Range	Minimum		8" / 203mm	5.5" / 140mm	4" / 102mm
	Maximum		24" / 610mm	17.38" / 440mm	21" / 533mm
Machine Dimensions			91.75" / 2330mm	33" / 838mm	59.5" / 1510mm
In/Outfeed Height	Frame		22" / 559mm		
With adjustable leg extensions [foot pad]	Minimum		25" / 635mm		
	Maximum**		29" / 737mm		
Speed			Up to 5 cases / min.		
Shipping Weight	Approx.		650 lbs. / 295 kg.		

For further detail, see Layout Drawing 75-208

* Vacuum case grates must be sized to fit inside width of cases within 1/2" - 1". One interchangeable grate comes standard with each machine, additional grates may be required for a range of case widths.

** Maximum height with outboard standard 12" footpad leg extension under the front of the vacuum plenum.

Construction

The case sealer frame is made of corrosion resistant and paint-free high tensile aluminum C-Beam extrusions, anodized after welding. The vacuum plenum case grates are 304 stainless steel and other components of the vacuum plenum are zinc-plated steel. All fasteners are S.A.E. stainless steel.

Electrical Specifications

A dedicated 115 VAC, 15A., 60 cycle, 1-phase circuit is required. Enclosures are NEMA 12, with a magnetic motor starter switch.

Vacuum Fan

A nominally rated 500 CFM fan is directly driven by a ¼ HP TEFC motor.

NOTE: poly bags must be of the gusseted-bottom type and for most applications the maximum material thickness is 3 mil. We request sending case and bag samples to the factory for evaluation to test that, in addition to case grate sizes, a standard fan unit is adequate for the application.

Tape Heads

Standard DEKKA Model 22, 2" tape width stainless steel tape heads with quick loading feature and center-pull tape guide system. Optional DEKKA 23, 3" tape width heads and Dekka 215 / 315 shorter tape tail heads are available at extra cost. DEKKA tapehead technology is protected by U.S. patent 5,938,097.

Sealer Conveyor Drive System

The sealer *Uni-Drive* synchronized side belt conveyor system is powered by 1/2 H.P.TEFC motor and gear reducer.

Conveyor Belts

3" rough top continuous loop with finger splice joint, and V-rib backing.

Safety Provisions

Conveyor drive and belt pulleys are fully guarded. Magnetic motor starter switch prevents accidental restarts after a power interruption. Potential hazards are warned with labels to ANSI standards.

Nameplates / Identification

The machine Model Number and Serial Number appear on a nameplate and the serial number is stamped onto the machine frame.

Documentation

- On-machine illustrated adjustment and operation instruction labels
- Operation & Service Manual - providing set up, operating and troubleshooting information
- Technical Reference – spare parts kits, assembly and parts reference drawings, electrical schematic diagram.

Options

- **Case Grate Sizes** – Case grates must be sized to fit inside width of cases within 1/2" - 1" [12mm – 25mm] for good “coupling” of the case to the vacuum plenum. One grate comes standard with each machine but additional grates are available in 1/2" [12mm] width increments from 6" to 16" [152mm – 406mm].
- **Integrated Weigh Scale** – incorporated into the vacuum plenum / packing station for check weighing of product. A batch fill controller version is available.
- **KDF Box Stand** for corrugated case blanks - Holds up to 50 cases for convenient one-at-a-time selection. Easy height adjustment.
- **Casters** – 4" diameter polyurethane wheel and swivel locking casters are available with either zinc plated or stainless steel bodies.
- **Ergo-Level Adjustable Machine Legs** - The BEL *Ergo-Level* system is a set of adjustable height legs that are mounted to the existing frame legs of BEL case sealers. They allow the sealer to be raised or lowered to suit operator or line height and to be inclined, if desired, for greater versatility. They are available with casters or swivel pads.
- **Heavy-Duty Vacuum Fan** – The standard fan unit is mounted on the machine frame and is suitable for most applications. A larger fan unit is occasionally needed for larger cases and / or heavier weight bags made of thicker film. However, the increase of bag thickness beyond 3 mil has a significant effect on performance and should be minimized. The larger 1100 CFM [nominally rated] fan unit is on a separate base with casters and connects to the main machine with a flexible duct.

Warranty

On Machinery and Parts manufactured by the Company, Wexxar Packaging Inc. (the "Company") warrants to the original purchaser ("Buyer") of the product described above (the "Product") that:

- (a) all non-moving, structural components of the Product (excluding hot melt systems and tapeheads) in all material respects, will be free of defects due to imperfect material or workmanship for a period of One (1) year from the date of invoice;
- (b) all powered mechanical parts of the Product, in all material respects, will be free of defects due to imperfect material or workmanship for a period of at least one (1) year from the time of shipping from the Company's factory;

and following Company's acceptance of a warranty claim, upon the Buyer's delivery of the defective Product to the Company's factory, the Company will repair or replace it at the Company's option.

The warranties set out above do not extend or apply to:

- (a) the routine replacement of parts due to normal wear and tear arising from use; this warranty does not extend to parts which may presumably be expected to wear out during the warranty period;
- (b) damage attributable to accident, misuse, improper maintenance, power surge, improper connection to a power source, placement of Product in hostile environment, or alterations not authorized by the Company, negligence, or accident;
- (c) accessories, attachments, parts or instruments sold with or attached to the Product that do not bear the Company's trade mark ("Components");
- (d) any warranty claim not made in writing to the Company at its head office within the applicable warranty period and within ten (10) days of Product failure.
- (e) This warranty does not cover shipping costs;

This warranty shall be the only warranty in effect and is made exclusive of all other warranties and guaranties written or oral, expressed or implied.

COMPONENTS	On request and to the fullest possible extent, the Company will assign to the Buyer any interest it has in Component suppliers' warranties for separately manufactured parts and accessories which form; are attached to; or constitute part of the Product. This includes tape heads.
CANCELLATION	Orders cannot be cancelled without consent of an authorized employee of the Company and in such cases the customer will fully indemnify the Company, unless agreed otherwise in writing by the Company.
TITLE	The title and right of possession of the goods quoted hereto shall remain with the Company and such goods shall remain Company property until all payments have been made in full. The purchaser agrees to do all that is required to maintain such right and title with the Company.
PRICE	All prices quoted are F.O.B. Company warehouse unless otherwise specified. Prices quoted are subject to change and do not include taxes or duties, if applicable.